

**8192 Bit System Architecture**

**By**

**Barry L. Crouse**

# **8192 Bit System Architecture**

**By**

**Barry L. Crouse**

## **Introduction**

Note from Author

I would like to take the time to say thank you for viewing my presentation on 8192 bit system architecture. The paper has 2 main parts one dealing with theory Quantum mechanics and the other 8192 bit system architecture explores way to create a new generation of IT computing with enhanced security which will provide the means to employ new idea's and concepts such as bit infusion which in reality is the principle of packing and unpacking bytes but on a more intimate level.

I would like to say thank you to everybody who made this possible.

Barry L. Crouse

# **8192 Bit System Architecture**

**By**

**Barry L. Crouse**

## **Table of Contents**

Note from Author

Part 1 Theoretical discussion on Quantum Mechanics with CMOS settings

Part 2 Exploring possibility's to create 8192 bit Systems

Part 3 Proposed Models for 8192 bit system

## **Theoretical discussion on Quantum Mechanics with CMOS settings**

**By**

**Barry L. Crouse**

Today is 10/10/2009 University Place Washington. I would like to open up a discussion on how to increase CMOS battery settings using 3 Volts 4096 bits to 8192 Bits. The reason is to enhance security.

I recently completed research on this topic and found that the CMOS battery settings are 3 volts at 4096 bits. Arrays are loaded in 16 by 256 for 4096 bits. I would like to propose a theory but before we begin Quantum mechanics should first be discussed.

The OSI Network layer Physical converts volts positive (1) and negative (0) into bits. Quantum mechanics according to the Wikipedia free encyclopedia deals with atoms and sub atomic namely electrons protons. In theory the atom or electron has 2 paths and if it chooses neither it is in a state of superposition as written by the author Bob Berman in the article entitled Strange universe in the magazine Astronomy.

Computer theory and design uses some of these principles and the people who written this showed great intelligence by stating atoms are entangled or uses circular motion instead of collision ;however, I do not think the idea of Atom or Electron infusion has not been fully investigated the reasons are that in kinetic energy when using Martial Arts science the ability to create energy called in Japan Ki or China chi has not been fully applied example suppose a martial artist wishes to break boards with only 1- 3 inches of space the ability to create energy within would have to be

understood and experienced as I have done. This kind of energy means the following precise motion and internal use of energy with proper rotation of body hint hips accomplishes this task

Another example is a Aikido or Hap kido expert uses energy to redirect the force in another direction example a Hap kido expert may use a 30 degree angle at the same time uses a push block when the attacker is punching coupled with a joint lock take down. The application is to use these principles of kinetic energy and apply them to increasing the CMOS 4096 bits to 8192 bits. Research has indicated the array is set to 16 by 256 for 4096 bits to increase this we would have to infuse the bits combining them by increasing the volts using heat to excite the atoms the only problem with this is if we increase the voltage and number of bits through the wires we start to have system degradation. The answers possibly would be to split the bridge creating 2 bridges for a total of 3 bridges on the motherboard ;therefore, the array could be set to 32 by 256 for 8192 bits this would allow for better security techniques implemented on the BIOS settings.

Please note the voltage and bit settings on the standard CMOS battery

1 volt	1024 bits
2 volts	2048 bits
3 volts	4096 bits

The principle of redirecting internal energy via heat would have to be redirected by creating a different path for bits to traverse not in superposition. Quantum physics states we cannot make accurate predictions as to the path it goes but we can provide space that allows it to choose not permitting the state of superposition this creates energy in constant motion.

Disclaimer this essay is regulated under International law trade treatys and or  
conventions

dated 10/10/2009

Barry L. Crouse

## **Exploring possibility's to create 8192 bit Systems**

**By**

**Barry L. Crouse**

Today is 10/20/2009 University Place Washington. I would like to examine three different ways to create a 8192 bit system with Certificate of Authority's. The following methods will be discussed

- 1). Dual core 3 volt battery's on motherboards
- 2). Larger cell battery's
- 3). using different metals to use higher voltage for motherboards

I would like to begin by first examining the specifications of 3 volt Lithium battery's under Ansi and the periodic table please reference the following Kalzium Periodic table used by Debian Linux and Ansi Wikepedia

The specifications called for Ansi states the 2032 Cell battery has a range of 3.0-3.7 volts temperature range between -40-140 degree Fahrenheit the material used is Lithium manganese Dioxide with Lithium as the (-) charge electrode and Manganese dioxide (+) positive charge. Voltage used to produce bits is

- 1). 1 volt = 1024 bits
- 2). 2 volts=2048 bits
- 3). 3 volts=4096 bits

The periodic table used by Kalzium specifies the following information for  
Lithium

Mass	Neutrons	Spin and Parity	Magnetic Moment
6.015121u	3	1+	.822056 Hn
7.016003u	4	3/2-	3.25644 Hn
Melting Point	453.7K		
Boiling Point	1,615.0k		
Electro negativity	.98		
Electron affinity	-60.0 kj/mol		
Ionization energy	520.8672 kj/mol		
Ionization	7,339.668 kj/mol		

After completing additional research, I found the next element on the table is called Beryllium producing the following results

<b>Mass</b>	<b>Neutrons</b>	<b>Spin/Parity</b>	<b>Magnetic Moment</b>
9.012182u	5	3/2-	-1.1776 Hn
Melting Point	1,560.k		
Boiling Point	3,243 k		
Electron negativity	1.57		
Electron affinity	19.0kj/mol		
Ionization energy	900.5052 kj/mol		
Ionization energy	1,759.1826 kj/mol		

Lithium battery's atomic structure consists of 2 concentric circle 1 atom outside 2 inside.



Please note the following information

Proton is a subatomic particle mass of  $1.6726231 \pm 0.0000010 \times 10^{-27}$ <sup>th</sup>  
with a positive charge of  $1.60217733 \pm 0.0000049 \times 10^{-19}$  in nucleus of Atom

Electron Subatomic Particle

mass of  $m_e (9.1093897 \pm 0.0000054) \times 10^{-31}$ <sup>st</sup>  
Negative charge of  $e = 1.60217733 \pm 0.0000049 \times 10^{-19}$  C

Subatomic Particle

mass of  $m_e (1.5749286 \pm 0.0000010) \times 10^{-27}$ <sup>th</sup>

We will now begin discussing our three possible means to create a 8192 bit system.

The 1<sup>st</sup> method is to use dual core battery's on the motherboard this would create a total of 6 volts. To accomplish this the following would have to be achieved

1. Removal of IDE controllers using Sata instead
2. usage of lithium cell battery models 2016,2025,2032 promoting dual pair battery's
3. BIOS settings could be treated as a shared resource loading the 1<sup>st</sup> 4096 bits on the 1<sup>st</sup> battery and loading the 2<sup>nd</sup> 4096 bits on the second battery creating a total of 8192 bits total this principle is similar to on board graphics and RAM memory shared resources
4. North bridge and South bridge currently uses 16 bits wide up and downstream this would have to be expanded for the allowance of 32 bits wide up and down stream

Please see attached diagram labeled 1-A

The next possibility is to use larger cell battery's

When we review the charts above pertaining to Lithium, We find that the standard size for Lithium is 3 neutrons with a mass of 6.015121u ;however, Lithium has a 2<sup>nd</sup> table using a mass of 7.016003u with 4 neutrons and a spin parity of 3/2- with strong magnetic moment of 3.25644hn

To accomplish using a lager Lithium battery we would have to understand that it takes 20 volts of static electricity to cause a motherboard to fail and the question of Electromagnetic laws and theory would have to apply here possible solutions could be to place a shield around the larger battery so it would not interfere with hard drives and other devices on the motherboard. Research has indicated film and digital cameras can employ a 6 volt battery using model 2cr5. Please review the table below Volts/bits. The wikipedia encyclopedia stated that electromechanical deals with protecting the motherboard from heat usages employing heat sinks, fans, and water cooler but the problem is that more voltage creates higher temperatures thus shielding the 6 volt battery would have to be implemented due to heat and voltage considerations also increasing the South bridge and North bridge wires 16 bits down and upstream should increase to 32 bits would have to be considered because of sending more bits through the wires. Please see Model 2-A showing a heat sink fan and shield used to protect against Heat and magnetic distortion.

Volts	Bits
1	1024
2	2048
3	4096
4	8192
5	16384
6	32768

Certificate of Authority's could employ a maximum of 32768 using random variable patterns see table below

Bits/Certificate	#Certificates issued
4096	4
8192	4
16384	4
32768	4

We could create 16 possibility's creating a random order ;therefore, the probability of cracking the code would be almost impossible unless of course a Cray supercomputer is employed. Probability can be calculated as follows  $16 * 15 * 14 * 13 * 12 * 11 * 10 * 9 * 8 * 7 * 6 * 5 * 4 * 3 * 2 * 1$

The next possibility is the usage of different metals to increase voltage on the motherboard. Research has indicated one of the closest metals is Beryllium copper. The periodic table of elements indicate that it has 5 neutrons with a spin parity of  $3/2^-$  and magnetic moment of  $-1.1776 \text{ hn}$

I researched the issue and found that Beryllium cooper represents a toxic to humans ;therefore, this would probably not be recommended Please view model 3-a possible solution to the problem is to encase the battery with a non toxic metal to prevent this problem. I would now like to call your attention to the 3 models to examine possibility's. The models propose new designs removing IDE controllers, expanding wires for the South and North bridges, using dual battery's to share CMOS settings.

In conclusion, I have introduced 3 different ideas using new concepts for new motherboard designs strengthening IT security. I would hope that manufacturer's and Engineer's of motherboards

would take this into consideration and the need for better security with the CMOS/Bios settings as demonstrated in the **Theoretical discussion on Quantum Mechanics with CMOS settings**. I feel that employing one of these 3 ideas would eventually propel the IT computer world to a better understanding of Quantum mechanics and bit infusion combining bits similar to the Assembler programming command packing and unpacking bytes and addresses.

Dated 10/26/2009

Barry L. Crouse



# Model 1-A Motherboard Layout

Dual Cell battery's 8192 bits with shared CMOS

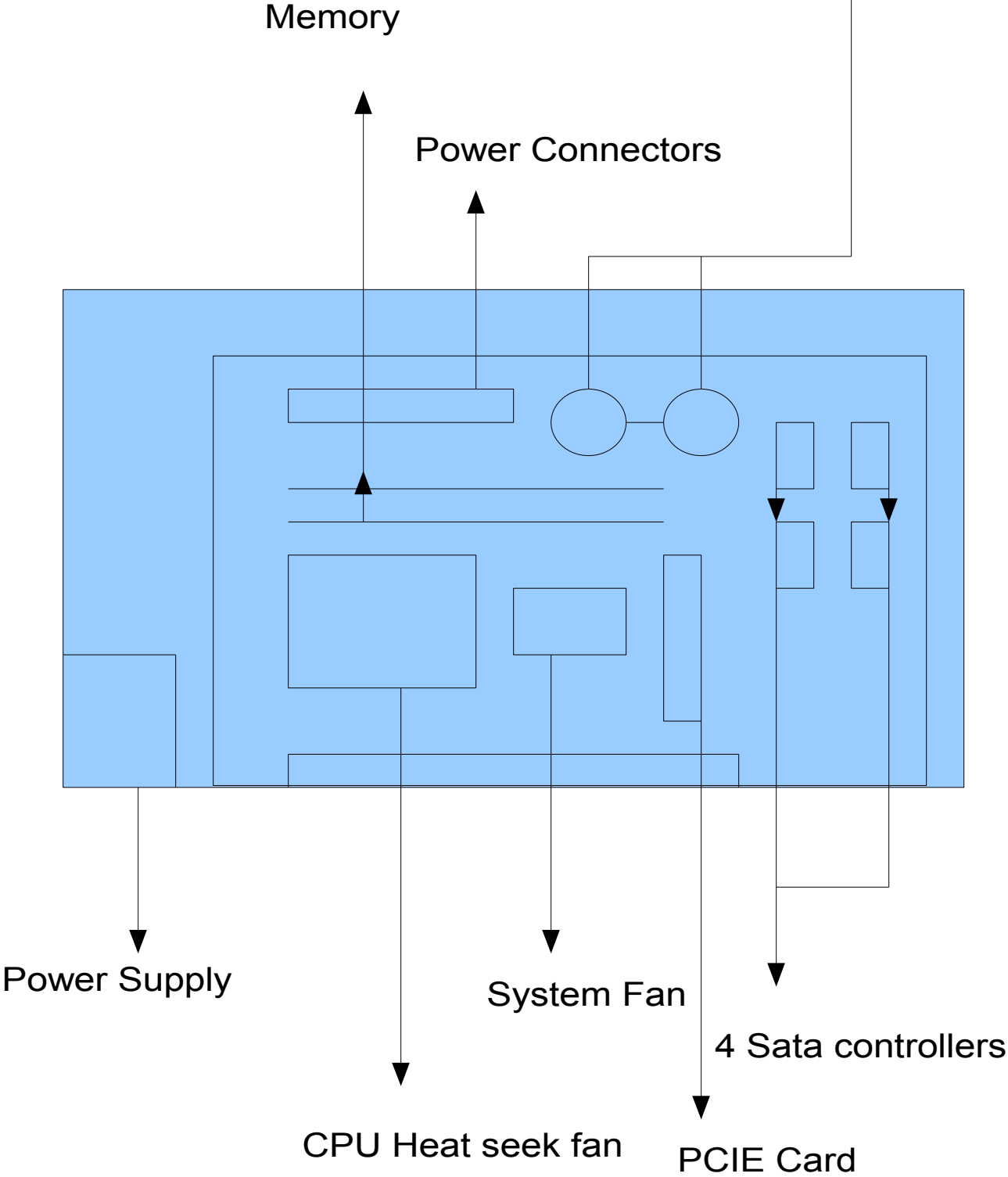



# Model 2-A Motherboard Layout

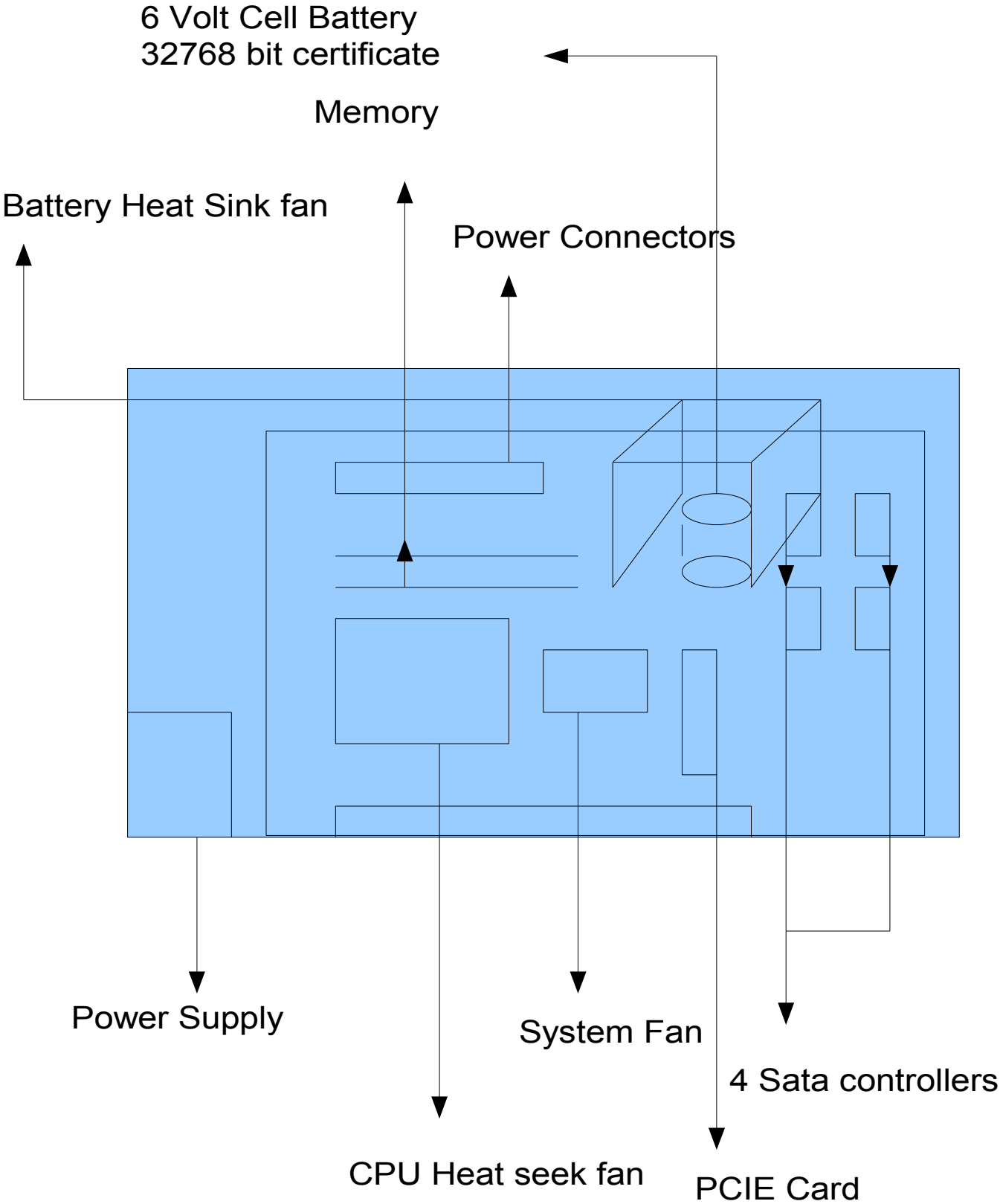





# Model 3-A Motherboard Layo 8192 Bit Architecture

